



13TH
EDITION

FIB

BENGUELA INTERNATIONAL
TRADE FAIR
22ND - 26TH MAY 2024

EXHIBITOR'S FILE

**THE BIGGEST BUSINESS EXCHANGE
IN SOUTHERN ANGOLA**

Multisectorial Exhibition | Conferences and Debates | Cultural Entertainment



13TH
EDITION **FIB**
BENGUELA INTERNATIONAL
TRADE FAIR

TECHNICAL FILE

TECHNICAL FILE

Name of the event: **FIB 2024**
Edition: **13th**
Location: **Ombaka National Stadium**
Exhibition Duration: **5 Days**

	TIMETABLE	DATE
Assembly	08.30 am to 08 pm	
	Own stand	18 nd to 20 th May 2024
	Organization Stand	19 nd to 20 th May 2024
	Tax assembly	15 nd to 20 th May 2024
	Fee assembly	01 nd to 20 th May 2024
Exhibition	10 am to 06 pm	22 nd to 23 th May 2024
	10 am to 08 pm	24 th to 26 th May 2024
Disassembly	8:30 am to 5:30 pm	27 th to 29 th May 2024

IMPORTANT DATES

Deadline for Registration
06 May 2024

Deadline for Catalogue Registration
22th April 2024

PAYMENT CONDITIONS AND AGGRAVATIONS

- Registrations only will be considered after the total payment of the registration.
- Registrations after the deadline, are subject to a surcharge of 10% on the price list.

PAYMENT DETAILS

Fairs & Events Arena, Lda.

BAI USD

ACCOUNT: 76538619.15.001
IBAN: AO06 0040 0000 7653 8619 1511 6
SWIFT: BAIPAOLU

BAI EUR

ACCOUNT: 76538619.15.002
IBAN: AO06 0040 0000 7653 8619 1521 3
SWIFT: BAIPAOLU

Note: This data is only for international registrations and payments in Dollars and Euros

CONTACTS

LUANDA

Tel: (+244) 924 901 280 | Tel: (+244) 937 517 980

Tel: (+244) 937 165 457 | Tel: (+244) 943 029 463 | Tel: (+244) 937 547 950 | (+244) 925 232 515

geral@eventosarena.co.ao

Cazenga - Oficinas Gerais dos Caminhos de Ferro de Luanda - Angola

BENGUELA

Phone: (+244) 933 949 642

daniel.kafina@grupoarena.co.ao

Sales Consultant

Ombaka National Stadium

Benguela

ATTENTION

This information doesn't invalidate the reading of the useful information of the event.

Iniciativa | Initiative



GOVERNO DE
ANGOLA

Promoção | Promotion

benguela.gov.ao
Governho Provincial de Benguela

Organização | Organization





13TH
EDITION **FIB**
BENGUELA INTERNATIONAL
TRADE FAIR

REGISTRATION FORM COMPANY DETAILS

Fill in CAPITAL LETTERS and black ink please

REGISTRATION

Registration Forum N° Date Comercial

Pav. N° Number of Pediments be fill in by the organization

COMPANY DETAILS FOR INVOICE ISSUE

Company Name

Address

Zip code

Location Tax Number

Country

Telephone Fax Mobile

Contact Person

Other Contact

Email

Site

NAME THAT IDENTIFIES THE COMPANY DURING THE EXHIBITION

CATALOGUE INFORMATION (PLEASE FILL WITH ENTERPRISE GENERAL CONTACTS)

Company Name

Address

Zip code

Tax Number

Brands

Products

ACTIVITY SECTORS

INDICATE YOUR COMPANY'S SECTOR(S) OF ACTIVITY

Agro-business

Energy and Environment

Health, Cosmetic and Beauty

Food & Beverage

Public / Government Entity

Services

Handicraft and African Costumes

Graphic Industry

Software

Banking and Insurance

Real State

Information and Communication Technology

Trade and Distribution

Extractive and Manufacturing Industry

Tourism and Hospitality

Communication & Marketing

Metalworking

Clothing and Shoes

Civil Construction

Furniture and Decoration

Education and Training

Oil & Gas

Other:

Iniciativa | Initiative

Promoção | Promotion

Organização | Organization



GOVERNO DE
ANGOLA

benguela.gov.ao
Governho Provincial de Benguela



eventos
arena
BY GRUPO
arena 20



Fill in CAPITAL LETTERS and black ink please

REGISTRATION FEE		USD	2	3	0	\$
		EUR	2	0	7	€

SPACE REQUIREMENTS

Interior Space **Without Stand**

Minimum Area 9m² 150 \$ | 135 € / m² [] m² X [], [] [] . [] . [] , []

Interior Space **With Stand**

Type of stand	Available area	Value per m ² USD	Value per m ² EUR
Basic	9m ²	230 \$	205 €
Bronze	18m ² to 36m ²	363 \$	326 €
Silver	27m ² to 45m ²	388 \$	349 €
Gold	36m ² to 54m ²	413 \$	371 €

Pediments Number 1 2 (+10%) 3 (+15%) 4 (+20%)

The request of more than 1 front implies the addition of 10%, 15% or 20%, by means of no. of fronts

Outdoor Space

Outdoor area 54m² 75 \$ / 67,50 € m² [] m² X [], [] [] . [] . [] , []

SUB-TOTAL

[] . [] . [] , []

CATALOGUE ADVERTISING

If you would like to post an ad in the event's official magazine, tick X

Back Cover	Inside Cover	Back Inside Cover
<input type="checkbox"/>	<input type="checkbox"/>	<input type="checkbox"/>

Even Page	Odd Page	Logo
<input type="checkbox"/>	<input type="checkbox"/>	<input type="checkbox"/>

Back Cover	1.480 \$	1.332 €
Inside Cover	1.200 \$	1.080 €
Back inside Cover	1.200 \$	1.080 €
Even Page	900 \$	810 €
Odd Page	980 \$	882 €
Logo	205 \$	184 €

SUB-TOTAL

[] . [] . [] , []

Activate your brand or service by becoming a sponsor (for more information see attachment)

Platinum	45.500 \$	38.000 €
Gold	35.000 \$	31.500 €
Activation Stage	16.500 \$	14.850 €
Lanyards and Bags	16.500 \$	14.850 €
Awards Cerimony	16.500 \$	14.850 €
Bags, Notepads and Pens	16.500 \$	14.850 €
Opening Cerimony	10.000 \$	9.000 €
T-shirt's	18.000 \$	16.200 €

SUB-TOTAL

[] . [] . [] , []

SUB-TOTAL [] . [] . [] , []

VAT 14% [] . [] . [] , []

TOTAL [] . [] . [] , []

We declare that we are in accordance with the conditions of this REGISTRATION FORM and we attach the proof payment participation referring o 100% in the amount of _____ relating to our participation.

Organization _____ Client _____ Date [] [] [] [] [] []

This information does not invalidate the careful reading of the General Regulations of Fairs. | Please sign and stamp all sheets



METHODS	BENEFITS
PLATINUM 45.500 \$ 38.000 €	36m ² of privileged location Feature as Platinum Sponsor on social media and in the event catalogue with. One A4 advertisement page; Official Brand Day; 250 invitations to send to major clients; Reference / thanks at the official opening and closing ceremonies; Possibility of creating special actions aimed at key customers and to be and to be included in the official programme of the trade fair; Possibility of creating animations aimed at the general public and to be included in the official programme of the fair; Invitations for parallel activities developed within frame work of FIB 2024; Negotiable: other forms of return; Additional: Sectorial partner (conditions to be specified in casa of interest); Dissemination of the company's advertising spot in the event's multimedia space. (to be provided by the sponsor)
GOLD 16.500 \$ 14.850 €	18 m ² of privileged location; Feature as a Gold Sponsor on social networks and in the event catalogue with one A4 advertisement page; 100 invitations to major clients; Reference / thanks at the official opening and closing ceremonies; Possibility of creating special actions aimed at key customers and to be included in the official programme of the fair; Possibility of creating animations aimed at the general public and to be included in the official programme of the fair; Dissemination of the company's advertising spot in the event's multimedia space. (to be provided by the sponsor).
ACTIVATION STAGE 16.500 \$ 14.850 €	Recognition as sponsor of the Activation Stage; 9m ² space; with special emphasis on the startup areas; Recognition in the general programme of the fair with the right to a page in the Fair's catalogue; Highlight and primacy in the protocol visits; Dissemination of the company's advertising spot in the event's multimedia space. (to be provided by the sponsor).
LANYARDS AND BAGS 16.500 \$ 14.850 €	All exhibitors and visitors are required to wear ribbons/cords and identification passes issued to give access to the event and its activities; The lanyards and bag sponsor will get the opportunity to get the company logo along with the event logo on this support
AWARDS CERIMONY 16.500 \$ 14.850 €	Recognition as a sponsor of the Award Ceremony; Brand image at the awarding cocktail venue, 9m ² space; Special highlight at the Award Ceremony; Recognition at the AWARD CEREMONY;
BAGS, NOTEPADS AND PENS 16.500 \$ 14.850 €	Distributed to participants at conferences and forums; The Sponsor will be able to personalise the notepads and pens with the company's logo together with the logo of the event; Public recognition of the sponsorship;
OPENING CERIMONY 10.000 \$ 9.000 €	Recognition as the Inauguration Ceremony sponsor; 9m ² space with special emphasis on the welcoming ceremony; Recognition in the general programme of the fair;
TSHIRTS 18.000 \$ 16.200 €	Distributed to participants at conferences and forums; The Sponsor will be able to personalise with company's logo together with the logo of the event; Public recognition of sponsorship;

Ps: The production of the final artwork for the advertising materials is the responsibility of the sponsors. The remaining materials and promotional actions will be executed according to the event's communication and marketing plan.



TYPE OF STANDS
SPECIFICATIONS

BASIC

>9m²

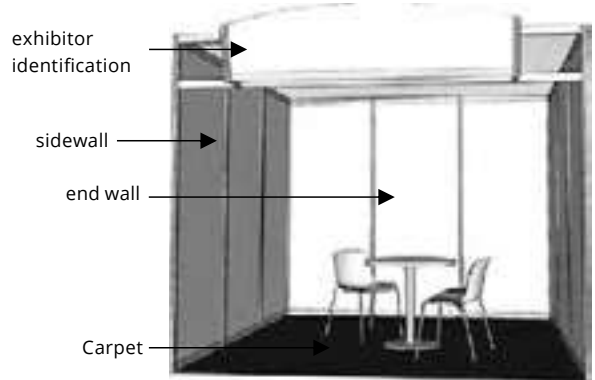
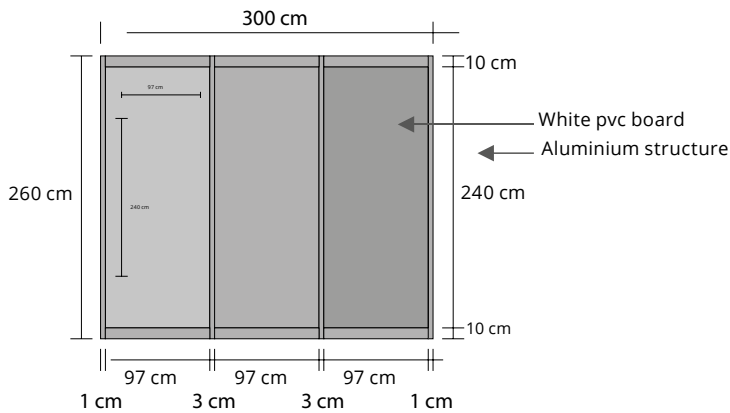

The printing of the graphic image of panels can be requested separately and subject to budget (consult It's Us)

01 table
02 Chairs

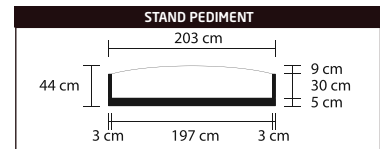

BRONZE

18m² | 27m² | 36m²

INCLUDED

- Construction System: MDF Lacquered in white paint
- Floor: Carpet
- Furniture: 01 meeting table, 03 chair, 01 stool, 01 shelf counter without door

Identification: 01 fronton with company name in Helvetica print



POSSIBLE SETTINGS

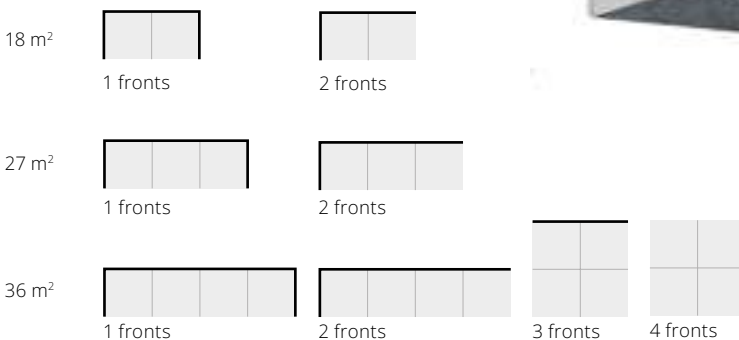

RULES

The walls of the stand are white and can not be painted, any intended change should be subject to evaluation and budget by It's Us.

It is also strictly forbidden to make holes in the walls, the plasmas should be on tripods or movable.

GRAPHIC PRINTING MEASURES (not included)

WALLS DIMENSIONS
2924 x 2400 mm
5848 x 2400 mm
2924 x 2400 mm

FRONTON
Front: 3 x 0,35
Side: 2,52 x 0,35
Pilar: 0,55 x 2,40

BALCONY
Front: 0,92 x 0,90
Side: 0,45 x 0,90



TYPE OF STANDS
SPECIFICATIONS

SILVER
INCLUDED

27m² | 36m² | 45m²

- Construction System: MDF Lacquered in white paint
 Floor: Carpet
 Furniture: 01 meeting table
 03 chair
 01 counter with shelf without door
 01 light box with 1 image (canvas) only on the front of the box
 01 stool
 01 1x1 storage with door
- Identification: 01 fronton with company name in Helvetica print

POSSIBLE SETTINGS

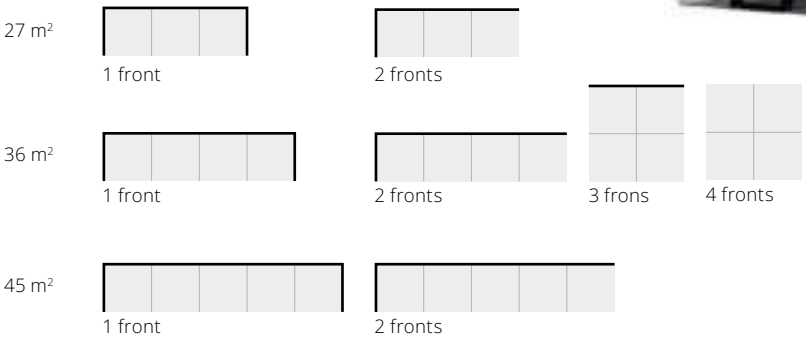

GRAPHIC PRINTING MEASURES (not included)

- WALLS DIMENSIONS**
 2924 x 2400 mm
 7848 x 2400 mm
 1000 x 2400 mm
 1000 x 2400 mm
 1924 x 2400 mm

- FRONTON**
 Front: 3 x 0,35
 Side: 2,52 x 0,35
 Pilar: 0,55 x 2,40

- BALCONY**
 Front: 0,92 x 0,90
 Side: 0,45 x 0,90

RULES

The walls of the stand are white and can not be painted, any intended change should be subject to evaluation and budget by It's Us.
 It is also strictly forbidden to make holes in the walls, the plasmas should be on tripods or movable.

GOLD

INCLUDED

36m² | 45m² | 54m²

- Construction System: MDF Lacquered in white paint
 Floor: Carpet
 Furniture: 01 meeting table
 03 chair
 01 counter with shelf without door
 04 stools
 01 high table
 02 light box with 1 image (canvas) only on the front of the box
 1x1 storage with door
 01 TV with tripod
- Identification: 01 fronton with company name in Helvetica print

POSSIBLE SETTINGS

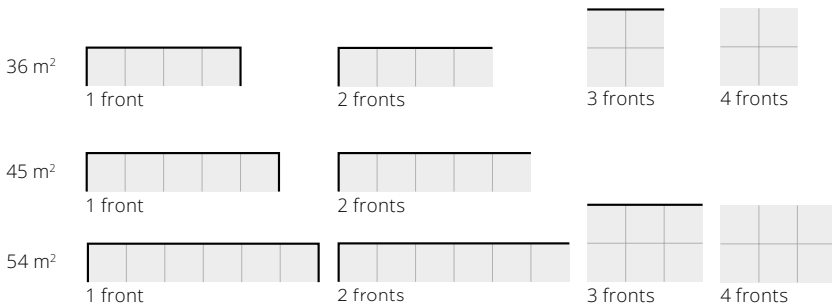

RULES

The walls of the stand are white and cannot be painted, any intended change should be subject to evaluation and budget by It's Us.
 It is also strictly forbidden to make holes in the walls, the plasmas should be on tripods or movable.

GRAPHIC PRINTING MEASURES (not included)

- WALLS DIMENSIONS**
 2924 x 2400 mm
 10848 x 2400 mm
 1000 x 2400 mm
 1000 x 2400 mm
 1924 x 2400 mm

- FRONTON**
 Front: 3 x 0,35
 Side: 2,52 x 0,35
 Pilar: 0,55 x 2,40

- BALCONY**
 Front: 0,92 x 0,90
 Side: 0,45 x 0,90



13TH
EDITION **FIB**
BENGUELA INTERNATIONAL
TRADE FAIR

AWARDS
FIB 2024

THE FIB 2024 AWARDS CEREMONY,

aims to publicly recognise the companies and entities that stand out the most during the exhibition.

- 1- During the week prior to the exhibition, the Organisation will pre-define the award categories according to the level of the exhibition and the sectors represented.
- 2- The Criteria are general and apply to the across the various Categories.
Criteria for evaluation:
 - a) Exhibition quality;
 - b) Stand Attractiveness;
 - c) Innovation, application of new Technologies;
 - d) Richness of contents, graphic or audiovisual;
 - e) Harmony in the use of the exhibitor's branding on the multiple elements (constructive, decorative, promotional, graphics and uniforms);
 - f) Available Promotional material;
 - g) Pro-activity in customer service.
- 3- Throughout categories defined and on the basis of the criteria presented, are selected the nominees for each category.
- 4- A jury previously selected by the organisation will vote individually.
- 5- All exhibitors will automatically be nominated for each category.
- 6- Votes result will only be known during the award ceremony FIB 2024 where the winners will get trophies and personalized diplomas.

We wish everyone good luck!

AWARDS FIB 2024

REGISTER NOW IN YOUR CATEGORY:

Best Participation Public Entities and Companies

Best Participation Industry

Best Participation Municipal Administrations

Best Participation Brand Activation

Best Participation Trade and Services

Best Participation Transport and Logistics

Best Participation Agriculture and Livestock

Best Participation Machinery and Equipment

Best Participation Insurance

Iniciativa | Initiative



GOVERNO DE
ANGOLA

Promoção | Promotion

benguela.gov.ao
Governho Provincial de Benguela

Organização | Organization

